



**Features**

UH is an anti-vibration mounting designed to accommodate axial static and shock loads in both directions. The dynamic natural frequency is constant irrespective of the static load.

When fitted with overload/rebound washers, a high strength fail-safe installation is provided. Moreover, it is possible to alter the characteristics of the mounting by providing a dome-shaped washer at the upper rubber section. This will provide impact resistance to deflection beyond the permissible limit.

Installation reduces build tolerances.

UH is available in 2 standard versions allowing different maximum loads i.e. type UH 50 to a load of 250 kg and type UH 70 to 400 kg per mounting.

**Novibra® type UH**

Mounting type UH is particularly suitable for the suspension of both mobile and static cabs as well as platforms on agricultural vehicles.

Effectively isolating vibration and noise, the UH-mounting also protects tanks and ancillary equipment against metal fatigue caused by chassis distortion.

Specific applications can be found on:

- Tractors
- Combine harvester
- Wheeled loaders
- Street sweepers
- Compactors
- Lifting cranes
- Construction vehicles
- Forestry vehicles
- Off-road equipment
- Fork-lift trucks
- Excavators

**Note: Maximum tightening torque of bolts:**

- UH 50 80 Nm
- UH 70 120 Nm

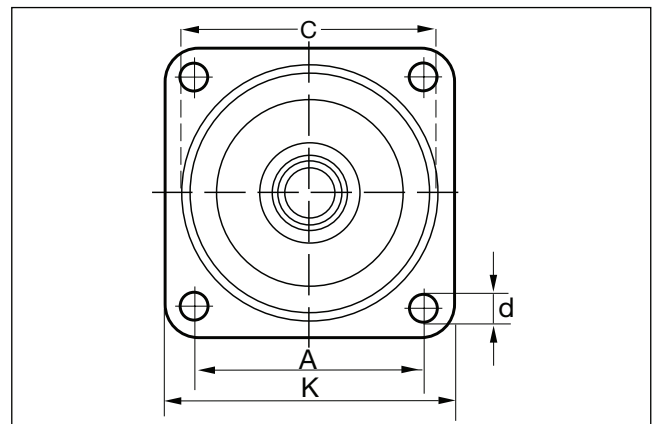
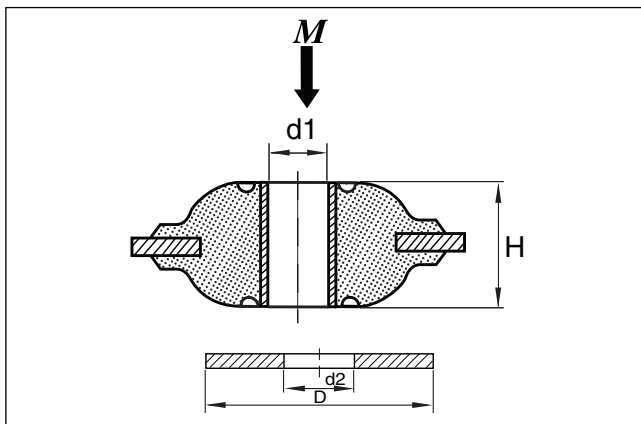

Type	Part no.	Dimensions in mm						Weight (kg)	M-Max (kg)
		K	A	H	C	d	d <sub>1</sub>		
UH-50	10-00086-01	100.5	80.4	37	91	10.5	15	0.41	250
UH-70	10-00088-01	100.5	80.4	37	91	10.5	17	0.41	400
			d <sub>2</sub>	D	t				
UH Washer	20-00608-01	17	75	6					