



### Features

The TF mounting is installed in minutes by following the instructions provided. There is no need to fix the machines to the floor since the rubber base of the mounting keeps the machine in place. Whenever necessary, the machine can easily be re-positioned. The level is adjusted with load applied.

The rubber element of the TF mounting is oil and chemical resistant. All metal parts are zincplated and chromated for protection against corrosion.

Models TF 250, TF 600 and TF 1200, also available in S/S (ISO 2604/11, BS 3605:1).

### Novibra® type TF

Novibra® type TF with level adjuster is suitable for a wide range of free standing workshop machines, e.g.

- Lathes
- Milling machines
- Grinding machines
- Multiple operation machinery
- Presses
- Plate shears
- Nibbling machines
- Punches and cutters
- Woodworking machines
- Plastic moulding machinery

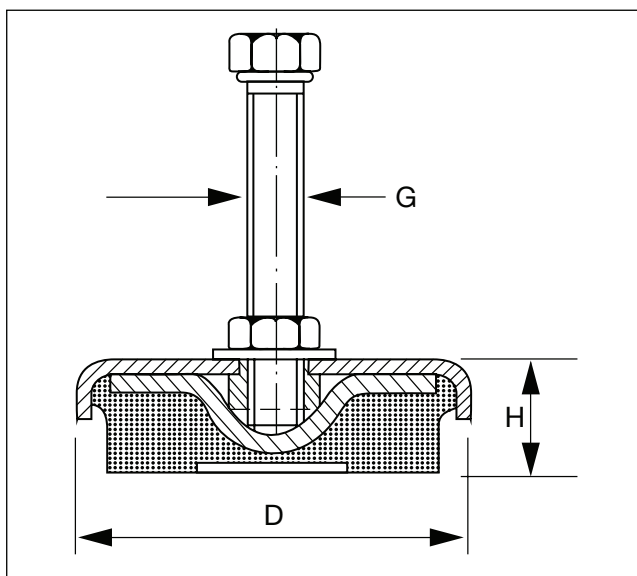

Type	Part no.	Dimensions in mm			Overall bolt length	Thread G	Weight (kg)	Max load (kg)
		D	H min	H max				
TF 250	20-00623-01	69	23	1)	100	M 12	0.40	250
TF 250 <sup>S/S</sup>	20-00678-01	69	23	1)	100	M 12	0.40	250
TF 600	20-00624-01	81	25	1)	100	M 12	0.49	600
TF 600 <sup>S/S</sup>	20-00679-01	81	25	1)	100	M 12	0.49	600
TF 1200	20-00625-01	108	29	1)	100	M 16	1.0	1200
TF 1200 <sup>S/S</sup>	20-00680-01	108	29	1)	100	M 16	1.0	1200
TF 3000	20-00626-01	151	35	1)	120	M 20	2.2	3000
TF 4000	20-00627-01	170	39	1)	120	M 20	2.9	4000
TF 6000	20-00628-01	205	44	1)	150	M 24	4.8	6000

1) Levelling of the bolt up to its total length.

Loading range per mounting (kg)

Type of machinery Mounting	General work-shop machines	Presses and punches							
		Numbers of strokes per minute							
		1–	125	126–	175	176–	225	226–	275
TF 250	250	25–	125	20–	100	15–	85	10–	60
TF 600	251– 600	126–	300	101–	240	86–	200	61–	150
TF 1200	601– 1200	301–	600	241–	480	201–	400	151–	300
TF 3000	1201– 3000	601–	2400	481–	1600	401–	1000	301–	750
TF 4000	3001– 4000	2401–	3200	1601–	2100	1001–	1300	751–	1000
TF 6000	4001– 6000	3201–	4800	2101–	3200	1301–	2000	1001–	1500

Mounting instructions

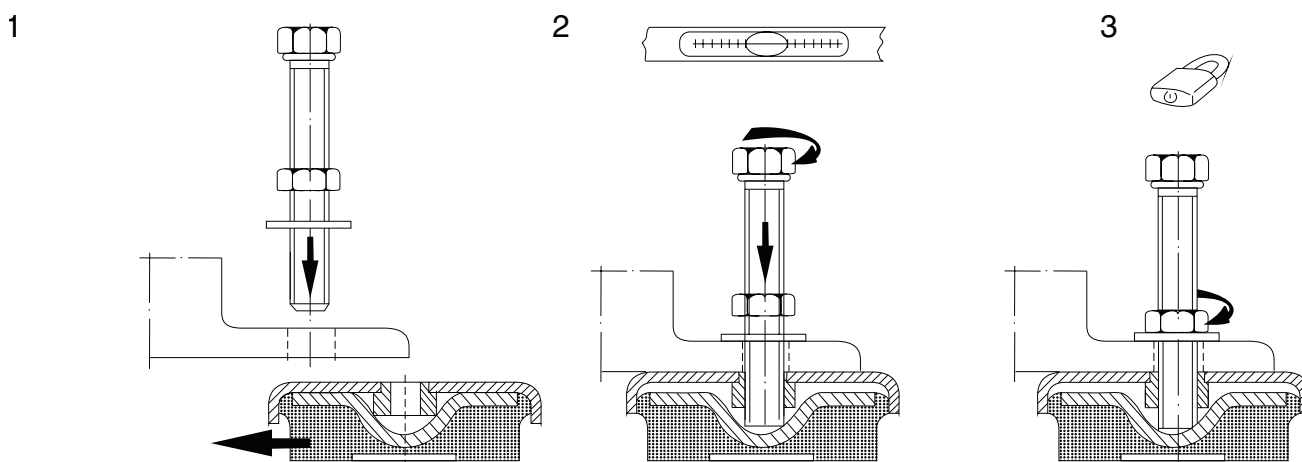

● **TFE**

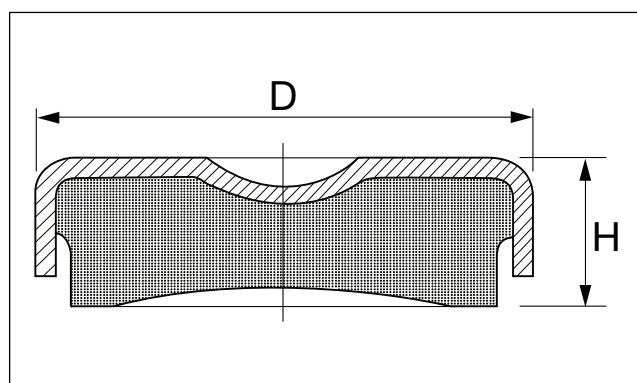

Mounting TFE is a simpler version of type TF without level adjuster. It is used for machines which do not require height adjustment or where such a feature is already provided, e.g. by an adjusting screw in the machine.

Both models also available in S/S (ISO 2604/11, BS 3605:1 )

Type	Part no.	Dimensions in mm		Weight (kg)	Max load (kg)
		D	H		
TFE 601	20-00629-01	80	25	0.375	800
TFE 1201	20-00630-01	109	29	0.925	1600