



**Features**

Novibra® type SAW mountings consist of a cylindrical shaped rubber section with integrally bonded interleaf metal plates bonded to two square heavy duty outer metal fixing plates. Designed for large compressive forces with minimum deformation, while providing low shear stiffness rates.

The combination of a stable low installation height, high compressive strength and low shear stiffness makes Novibra® type SAW a versatile high performance anti-vibration mounting. Ease of installation due to 4 clearance holes in each fixing plate.

By connecting 2 SAW-elements in series, i.e. one on top of the other, an increased isolation efficiency is achieved in both shear and compression planes. Where larger deflections are required in the vertical plane, Novibra® type SAW mountings are mounted at a calculated angle configuration to provide the optimum spring rate.

**Novibra® type SAW**

Novibra® elements type SAW are heavy duty mountings for static and shock loads in compression. Provides high isolation in the horizontal shear direction.

Typical fields of application are:

- Crushers
- Edge runners
- Mills
- Hoppers and feeders
- Grinders
- Vibratory rollers
- Screens
- Other very heavy machines and equipment

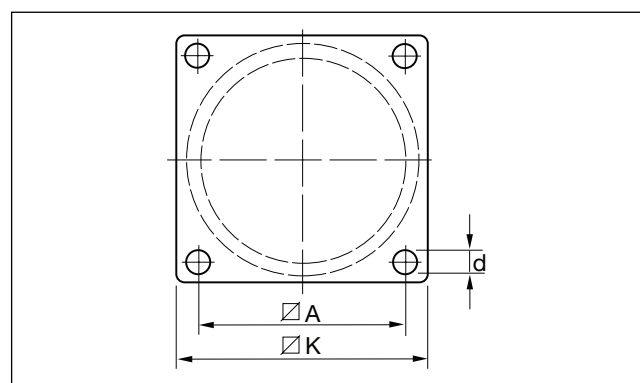
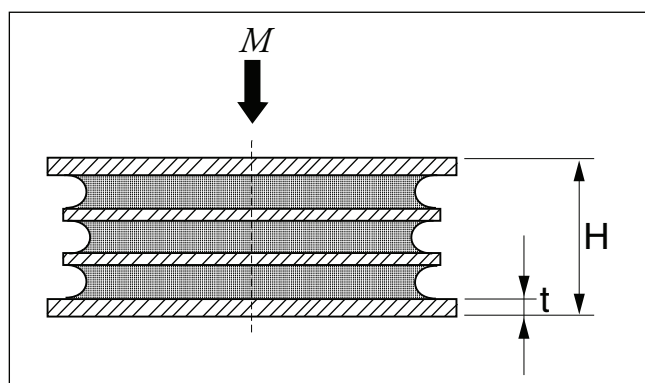
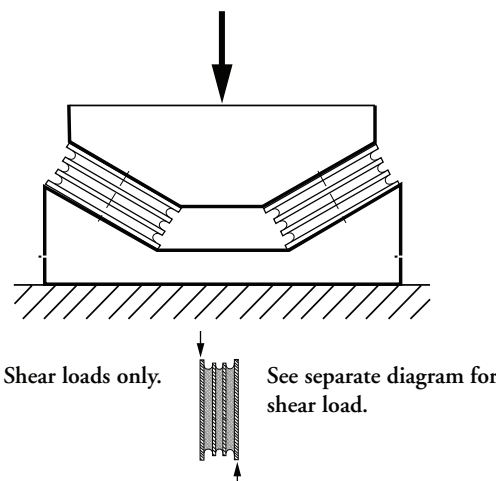

Type	Part no. 40° IRH	Part no. 60° IRH	Dimensions in mm					Weight (kg)	M-Max(kg)	
			A	K	H	d	t		40° IRH	60° IRH
SAW 125	10-00141-01	10-00142-01	118	148	52	13.5	5	2.6	2250	4500
SAW 150	10-00143-01	10-00144-01	136	166	63	13.5	6	4.1	3750	7500
SAW 200	10-00075-01	10-00076-01	184	220	82	17.0	8	9.2	6000	12000
SAW 300	10-00077-01	10-00078-01	270	310	120	22.0	10	27.0	15000	30000