



Novibra® type M

Type M is ideal for applications involving isolation of low frequency vibrations in all planes. Also suitable for shock attenuation due to the designed ability to offer large deflection. Provides passive vibration isolation on electronic instruments, measuring equipment and test cells.

Specific fields of application are:

- Compressors
- Refrigerators
- AC-units
- Ventilators
- Fans
- Powder handling machinery
- Vibratory screens
- Packaging applications
- Electric motors
- Weighing scales
- Test cell equipment
- Noise control units
- Pumps
- Food processing equipment

Features

Novibra® type M is specifically designed to give large deflection at low loads. Although the mount design allows high deflection, the mountings are compact in weight and easy to install.

Its unique construction and the latest production methods make Novibra® type M a high performance antivibration mounting having a number of advantages:

- Tight tolerances on dynamic stiffness rate for accurate vibration calculations.
- Wide load rating options, 3.5–2500 kg.
- Corrosion protected to cope with arduous environments on land or marine applications (Fe/Zn8C2 as per ISO 2081).
- Clear and durable product marking so that mountings can be identified even after several years in operation.

When using M mount together with the height adjuster HA, it is necessary to use a washer. The diameter of the washer must be 20% larger than the diameter of the upper plate (D).

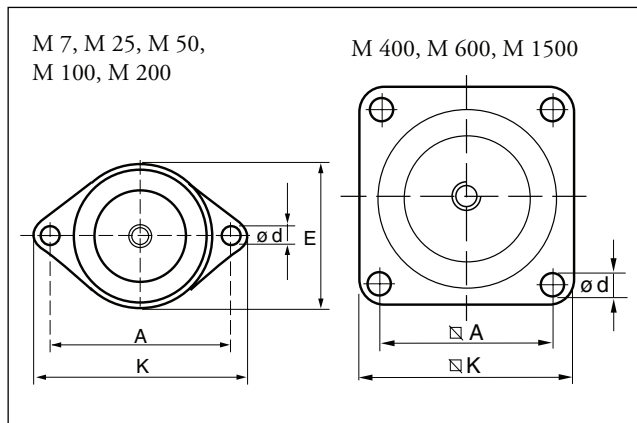
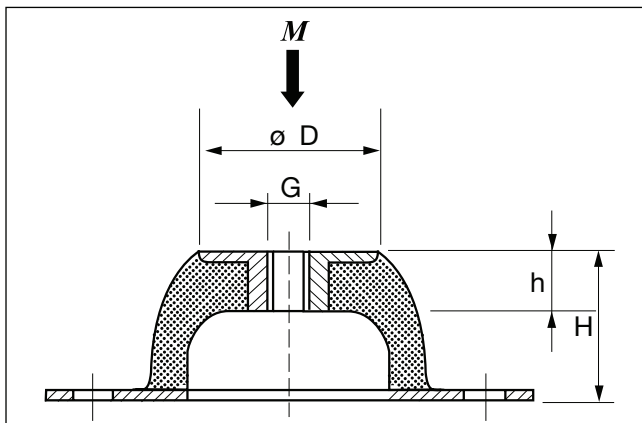

Type	Part no. 40° IRH	Part no. 60° IRH	Dimensions in mm				H	h	d	G	Weight (kg)	M-Max(kg)	
			D	E	A	K						40° IRH	60° IRH
M 7	10-00139-01	10-00140-01	18	43	50	64	20	7	7.0	M 6	0.02	3.5	9
M 25	10-00094-01	10-00095-01	33	56	66	85	25	11	8.0	M 8	0.07	20	50
M 50	10-00096-01	10-00097-01	45	76	92	114	35	14	10.0	M 10	0.16	40	80
M 100	10-00100-01	10-00099-01	53	96	110	136	40	15	11.5	M 10	0.26	70	150
M 200	10-00102-01	10-00103-01	58	101	124	151	45	13	11.5	M 10	0.42	130	220
M 400	10-00104-01	10-00105-01	78		120	150	63	18	14.5	M 12	1.06	280	500
M 600	10-00080-01	10-00081-01	100		160	200	85	25	14.5	M 16	2.35	380	750
M 1500	10-00082-01	10-00083-01	186		250	310	160	43	18.0	M 24	9.43	1400	2500