

Instrument Mount

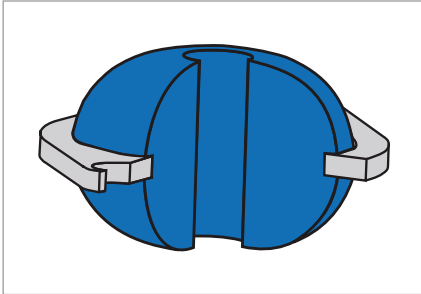

Fig. 1 Instrument Mount

Product description

The mounts protect sensitive instruments against impact and dynamic excitation.

Product advantages

- Reduced transmission of structure-borne noise
- Compact
- Easily installed
- Uniform stiffness in the radial directions
- RoHS-compliant.

Application

Instrument mounts are utilised for vibration insulation of electronic components, measuring devices and precise mechanical apparatuses and for instrument panels or control panels in industrial applications. A common requirement of these mounts is that they keep vibrations or shock loads introduced via the anchorages away from the instrument or device. The mounts help to protect sensitive instruments from external shock loads in mobile and non mobile use. Another possible use is insulation against structure-borne sound, for example in small electric engines or pumps that have to be mounted on "resonators" (sheet metal).

Material

Standard material	Hardness
Natural rubber NR 11	40, 50, 60 Shore A

Operating conditions

Axial forces	80 N ... 260 N	Maximum permissible force
Max. temperature	+60 °C, transient +80 °C	
Min. temperature	-45 °C	

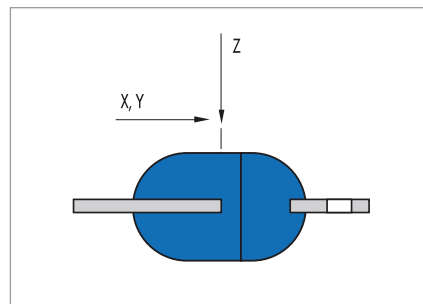

Fig. 2 Primary load directions

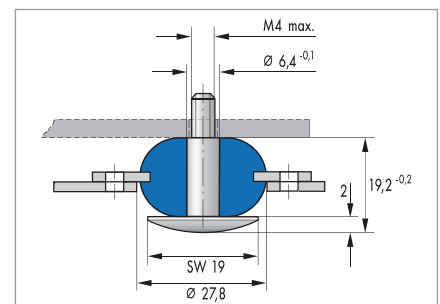

Fig. 3 Installation diagram with stud SW19

Instrument mounts are generally designed with the same stiffness in all translatory deformation directions. The limitation of the spring displacements in the radial direction generally appear more than in the axial direction. The static load of the weight should primarily be absorbed in the longitudinal axis.

Design notes

The instrument mount comprises a carrier washer with connected or vulcanised elastomer body with central through-hole. Through-holes are attached outside in the flange of the carrier washer. A stiffening metal part can be vulcanised into the middle of the elastomer body.

Fitting & installation

- Instrument mounts are designed to be anchored by threaded fasteners
- Slight, non-load-related, installation-related offset of the central securing screw relative to the flange is permissible. The same applies to slight angular offset
- Locate instrument mounts in line with the axis of the static primary load
- Make sure that the cut-out to be occupied by the elastomer body is free of burrs and at least 1/10 mm larger than the outside diameter of the elastomer part
- Allow for the requisite spring displacement when selecting the length of the central screw and sizing the cut-out to accommodate the mount
- When securing the flange use washers and make sure that a large, flat and smooth surface is available for force transfer from threaded fastener to elastomer part.

Article list

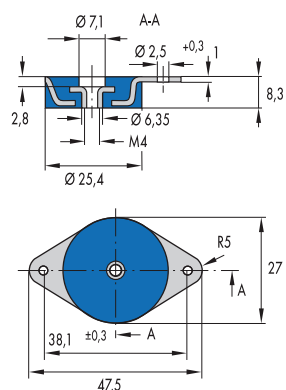

Fig. 4 Instrument Mount 039 18 022

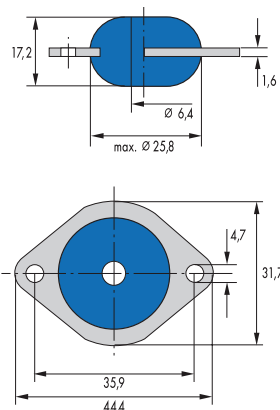

Fig. 5 Instrument Mount 039 18 023

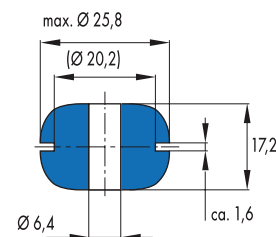

Fig. 6 Instrument Mount 039 18 751

Nominal maxima		Stiffness	Nominal maxima		Stiffness	Product No.	Material	Article No.	
Axial pressure			Radial shear						
F_z max	S_z max	c_z	F_{xy} max	S_{xy} max	c_{xy}				
[N]	[mm]	[N/mm]	[N]	[mm]	[N/mm]				
120	0,5	240	200	1	200	3918 022	40 NR 11	93657	●
80	2,0	40	45	2	20	3918 023	40 NR 11	93658	●
130	2,0	65	75	2	40	3918 023	50 NR 11	93659	●
260	2,0	130	130	2	70	3918 023	60 NR 11	93660	●
80	2,0	40	45	2	20	3918 751	40 NR 11	49039880	○
130	2,0	65	75	2	40	3918 751	50 NR 11	49039881	○
260	2,0	130	130	2	70	3918 751	60 NR 11	49039902	○

● Available from stock ○ On request: Tool is available, delivery at short notice